



JOB	
MODEL	140 GAS WOOD
ITEM #	

High temperature pizza oven. Cooking range is from 650f to 900f.

CLEARANCES: Install the oven with a minimum 2” clearance on sides and back from any combustible material. Noncombustible materials ONLY for façade front. 24” clearance from the top of the oven to combustible materials. Install on a Non Combustible floor only extending 36” past the oven front.

Hearth Size	140 cm
12” Pizzas	15
16” Pizzas	6

Installation through any 36” opening door way. All ovens are installed by a factory representative only.

FOR DIRECT VENTING: It is never appropriate to use “B vent” in any part of an exhaust system connected to your oven. All duct material must be manufactured to the specifications of a grease duct. This is a wood/gas combination oven and must be vented as a “solid fuel” appliance.

Due to the possibility of sparks entering the system, exhaust systems serving solid fuel equipment must be vented separately from other non-solid fuel equipment. The duct serving this oven should be inspected at least twice a month during the first two months of operation, to establish rate of creosote buildup and necessary cleaning schedule. Submit venting plans to your local authorities before proceeding with your installation, as there may be additional requirements in your area.



4008973

CONFORMS TO UL SUB 2162,ANSISTD283.311

CONFORMS TO NSF /ANSI STD 4 CERTIFIDE TO CSA STD 1.8ULC/ORDSTDC2162 FOOD SERVICE EQUIPMENT



Revolving Oven Gas Wood Model 140



Recommendations

DIRECT VENTING: Use a 10" Interior Grease duct connection pipe, to oven vent flue. The material must be constructed and installed in accordance with UL 1978 / NFPA 96 and/or the International Mechanical Code. **Direct Venting Connection** can be to a (power ventilated) grease rated duct, (where permitted by local code). All fans on direct vent should be roof mounted and have a variable speed control switch. preferably near oven front. The fan should be rated for 475.F

Link for exhaust fan. <http://www.enervexfansource.com/pizzaovenfans.htm>

Optional Local code - A listed Type 1 Exhaust Hood or one that is constructed and installed in accordance with NFPA 96 or the International Mechanical Code, and all relevant local and national codes.

Follow all local codes for venting as well as venting manufactures installation specifications of any vent pipes. Submit all plans for approval before installation of any venting. CONSULT WITH A QUALIFIED MECHANICAL ENGINEER AND SUBMIT YOUR VENTING PLANS TO LOCAL CODE AUTHORITIES BEFORE PROCEEDING WITH INSTALLATION OF ANY DUCT WORK.

WEIGHT: 4000 lbs. 75" DEPTH X 83" WIDE

The oven should be installed in accordance with all relevant local and national codes and in a manner acceptable to the authority having jurisdiction.

Specifications for Gas Models

UTILITIES

Gas ½ NPT CONNECTION

116,000 BTU Natural Gas (max) 177,000 BTU Propane (max)

ELECTRICAL SUPPLY: Have a licensed electrician install

(1) 115v-15amp outlet with proper grounds

(1) 230v- 20 amp single phase line. Plug receptacle type NEMA 6-20

Max Load 13.5 amp 230v / 115v 1.5 amps.

Important: Install dedicated electrical lines to prevent any overload or surge.



Electrical Code Limitations: This appliance must be electrically grounded in accordance with local codes, or in the absence of local codes, with the National Electrical code, ANSI/NFPA 70
Follow all local codes and submit all plans for approvals

Model 140 Oven

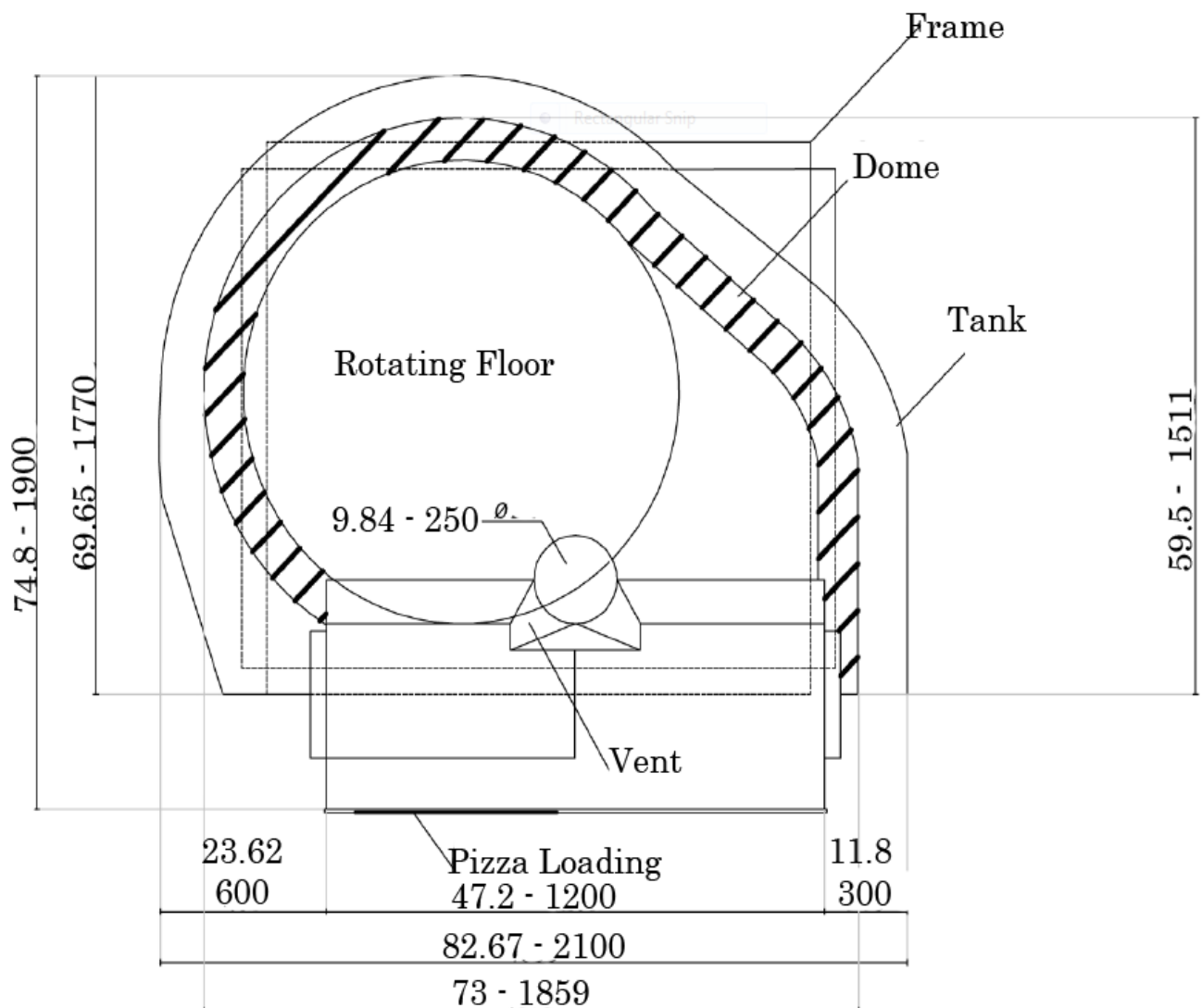

Model 140 Oven

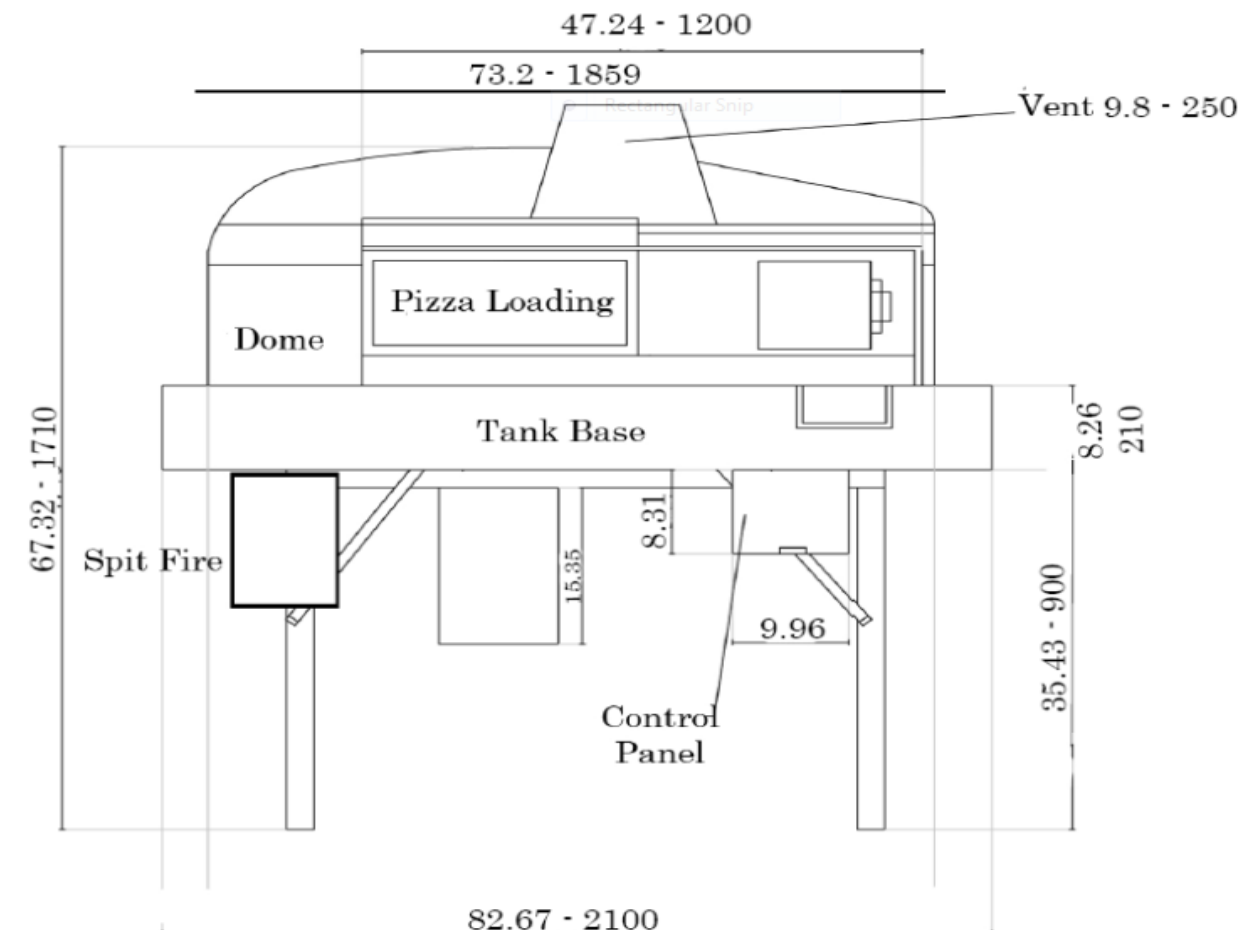

Always submit all plans to local authorities before installing oven and venting.

Enclosing Oven: Oven can be framed in with non-combustible materials. Metal studs, Backer board, tiles or brick. **Do not use sheet rock on oven façade.**

Important an assessable entrance must be at oven bottom approximately 36''x 36'' for maintenance of oven and proper air flow.

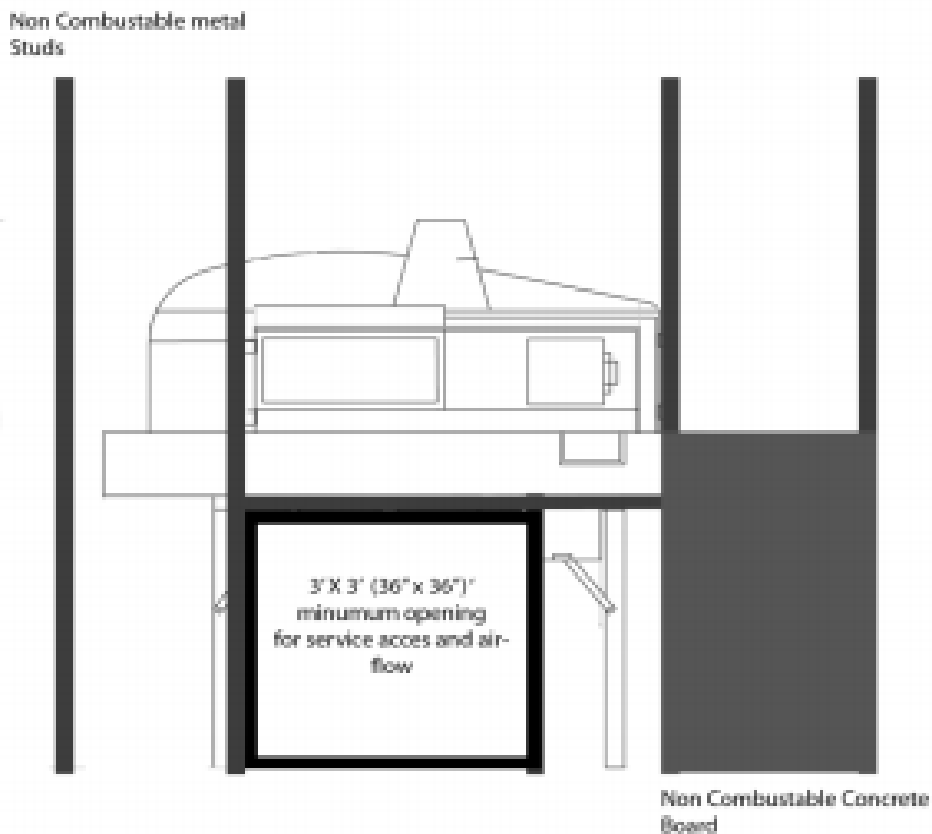

Figure 2

Oven must be built on noncombustible floor.

Check Weight load and always submit plans for all approvals.

Do Not Operate oven with steal door closed. Only use at nights end to keep heat in.

Read Operators Manual before using oven for first time. Following curing procedures.